

Project:	SENDORA	Deliv. ref.:	D6.2
EC contract:	216076	Deliv. title:	Network dimensioning and protocol design
		Deliv. version:	1.0
		Submission date:	07/07/2009

## 5 PROTOCOL STACK FOR THE VALIDATION TRIALS

In addition to the optimised protocol stack described above and fully dedicated to the SENDORA WSN aided cognitive radio system design, here we specify the protocol stack to be used for the validation trials implementation. This protocol stack is based on OpenAirInterface stack that has been depicted in D7.2 (section 5.3) and that will be the basis for implementation of the two demonstration scenarios specified in the first period of the project. In this section, we explain what has to be adapted or added to the existing protocol stack to implement the sensing functionality of the WSN aided cognitive radio system.

The sensor protocol stack depicted here will allow to validate the global WSN aided Cognitive Radio concept without providing an optimal and fully dedicated protocol stack. Indeed, the same initial protocol stack will be also used for secondary cognitive nodes protocol stack implementation. The WSN protocol stacks, the one for optimised simulation purpose (described in Section 4) and the one for demonstration purpose (described in this section), are therefore different, but they will rely on common principles: some of these principles have already been defined like the message exchanges between the system components (WSN, Secondary network, FC).

The objective of this section is to describe the sensor protocol stack for both demonstration scenarios. In particular, we define the protocol stack that will allow the transmission of the signalling messages needed for the validation of the WSN aided cognitive radio concept.

Figure 17 specifies the mapping of the signalling messages to be implemented onto the SENDORA system architecture.

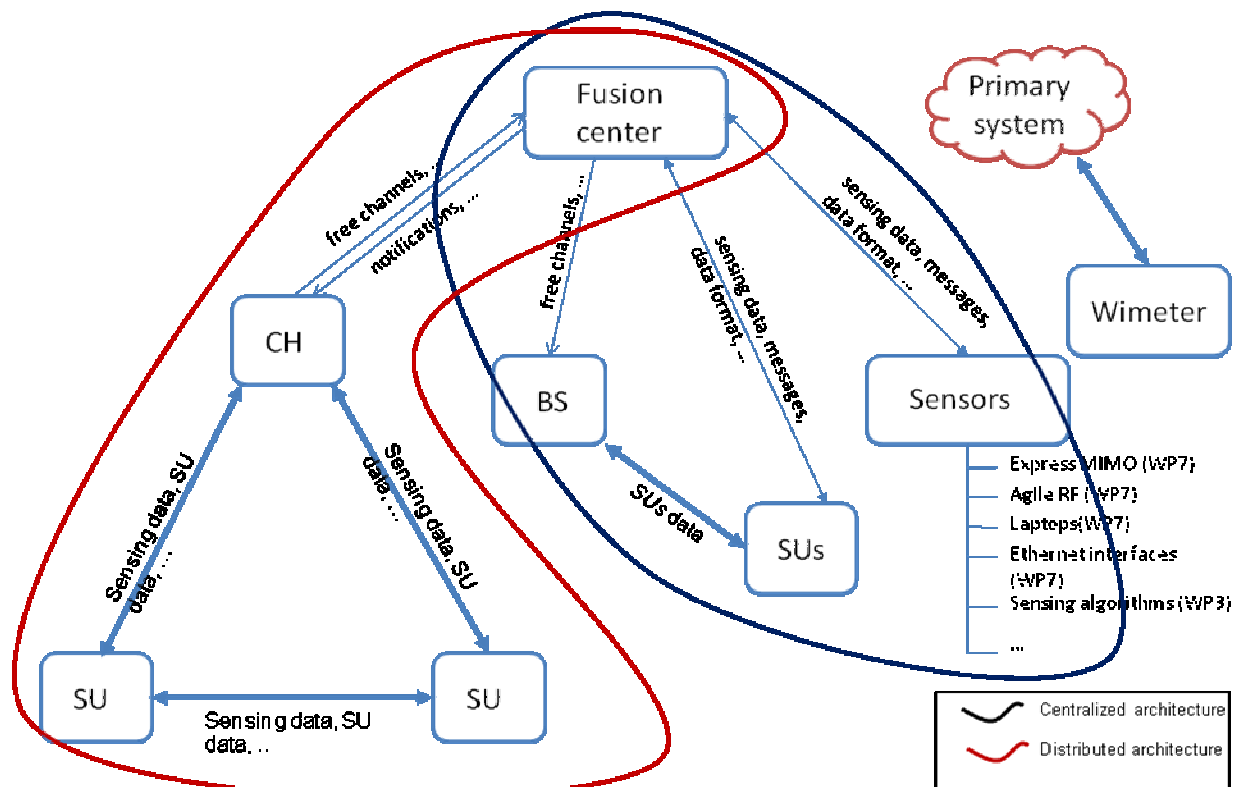

Figure 17: A schematic overview of the signalling messages needed for demonstration scenarios #1 and #2

Project:	SENDORA	Deliv. ref.:	D6.2
EC contract:	216076	Deliv. title:	Network dimensioning and protocol design
		Deliv. version:	1.0
		Submission date:	07/07/2009

In the following sub-sections, the required protocol stack adaptations are listed, both demonstration scenarios are analysed (in particular the role and functionalities needed at sensor node) and implementation requirements are specified.

## 5.1 PROTOCOL STACK

### 5.1.1 Needed adaptations

The OpenAirInterface protocol stack shall be adapted to play the role of a sensor in the sensor network in scenario #1 and of an ad hoc terminal including sensing capabilities in scenario #2. Adaptations mainly consist in (1) adding sensing capabilities, (2) building channels for the transmission in the WSN of information related to the cognitive cycle (sensing data, sensing control, decisions on free channels, ...), and (3) adapt protocol stack components to manage these channels.

To convey the signalling highlighted on Figure 17, two new channels are defined and termed CSCH (Cognitive Sensing Channel) and CPCH (Cognitive Pilot Channel). The CSCH is an uplink channel used to carry sensing measurements. The CPCH is a downlink channel used to require sensing information (bandwidth, detector type, performance, etc...) to sensor nodes. It will also be used in the cognitive network to carry decisions about free bands and spectral opportunities.

The adaptations of the protocol stack depicted in D7.2 that are required to implement both scenarios are the following:

- add flexibility to the frame to introduce time periods for sensing purpose
- integrate a local cognitive scheduler called Cognitive Radio Resource Management (CRRM) that:
  - decodes the information related to the cognitive operation in the signaling sent by the cluster head or the FC (sensing control, cluster scheduling, local decisions) over the CPCH
  - pilots the PHY/RF Tx/Rx chains according to the scheduling between the following three phases:
    - sensing
    - transmission of sensing information on dedicated band
    - secondary communications on cognitive band
  - computes sensing information received from sensing at FC in scenario #1 and at cluster head or distributed nodes in scenario #2, depending on the adopted strategy.
- integrate a local cognitive controller called Cognitive Radio Resource Control (CRRC) that:
  - pilots the sensing (parameters of detection)
  - fetches the sensing information from the sensing module
  - open and configure dedicated channels through the RLC control:
    - CSCH for sensing information transmission
    - CPCH for sensing information requests and decisions broadcast (at Fusion Centre or Cluster Head, depending on the considered scenario).
- add the capability of parameterization of the PHY/RF to perform sensing on demand controlled by higher layers (in particular by the CRRM), e.g. the frequency and the bandwidth.
- integrate a sensing module composed of:
  - one or several detectors
  - interfaces with RF/PHY for data acquisition
  - interface with the CRRC for sensing information delivery

Project:	SENDORA	Deliv. ref.:	D6.2
EC contract:	216076	Deliv. title:	Network dimensioning and protocol design
		Deliv. version:	1.0
		Submission date:	07/07/2009

The protocol stack will finally be composed of the following entities, as depicted on Figure 18:

- NAS: IP/MPLS network device.
- PDPC: convergence protocol component for IP interfacing.
- CRRM: new entity, dedicated to cognitive operation (sensing control and computation, cognitive actuation) management on the terminal. The cognitive actuation performed in CRRM may be common with the one used in the optimized simulated protocol stack.
- CRRC: new entity dedicated to carry new messages to support cognitive procedures signalling and control, in addition to MAC layer signalling, measurements computation, topology management, dynamic configuration and maintenance of logical channels.
- RLC: link control including IP packets segmentation, ARQ protocol and MAC PDU building.
- LMAC: mapping of logical channels into transport channels. Manages PHY parameterization and measurements.
- PHY: physical layer, embedding a sensing module based on several detectors. Detectors may be common with the ones used in the optimized simulated protocol stack.
- RF: dual-antenna radio front-end.

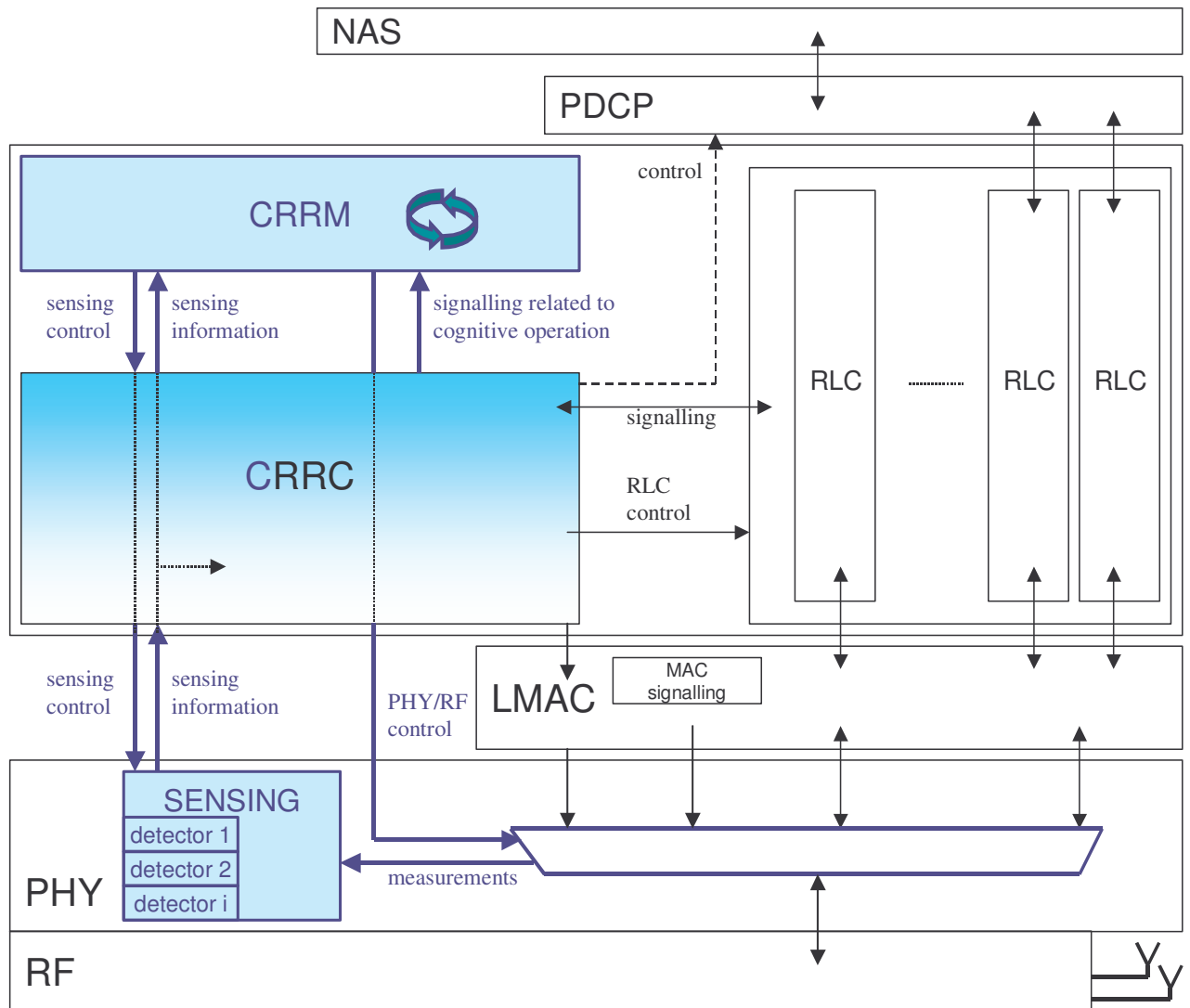

Figure 18: Protocol stack adaptation for demonstration scenarios implementation

Project:	SENDORA	Deliv. ref.:	D6.2
EC contract:	216076	Deliv. title:	Network dimensioning and protocol design
		Deliv. version:	1.0
		Submission date:	07/07/2009

Elements colored in blue are the main elements to be modified or added to the existing protocol stack for scenarios implementation. This protocol stack allows both sensing, transmission of sensing information and secondary communications.

## 5.2 SCENARIO #1

### 5.2.1 *Sensors in Scenario #1*

Sensing in system demonstration scenario #1 is performed through a dedicated sensor network, composed of sensor nodes that compute and convey sensing information until the FC. According to the sensing information received, the FC takes centralized decisions and controls the secondary network transmissions.

In this scenario, the sensor network and its connection to the FC are wired. The over-the-air capability is validated in scenario #2. OpenAirInterface protocol stack and PHY layer emulator described on Figure 19 will be adapted and used to play the role of WSN. Although sensing information is not transmitted over-the-air, all the needed mechanisms and protocols will be validated thanks to this emulator. The amount of transmitted data shall be reduced according to the D2.1 system specifications. Note that in this scenario, the secondary nodes will be based on OpenAirInterface protocol stack as well.

### 5.2.2 *Stack implementation*

The implementation of the sensor node in Scenario #1 will rely on the protocol stack represented on Figure 18, in which only the sensing and transmission of sensing information will be performed (and consequently only one RF chain will be used). Indeed, secondary communications are performed through other separate nodes.

As explained above, the implementation will be based on a PHY layer emulator instead of wireless links for sensing information transmission. The emulator to be used for that purpose is specified below. The acquisition phase of sensing will be done through AGILE RF board.

#### 5.2.2.1 **PHY layer emulator**

The OpenAirInterface wireless network emulator is a tool with the dual objective of performing protocol and application performance evaluation, in addition to real-time layer 2/3 protocol implementation validation. The emulation environment comes in both real-time and non-real-time flavors based on RTAI/Linux open-source developments.

The OpenAirInterface emulation environment can be configured for real-time PC-based targets and user-space non real-time PC based targets. Both allow for virtualization of network nodes within physical machines and distributed deployment on wired Ethernet networks. Virtualization is done within the same operating system instance (i.e. we do not need to make use of virtualization tools such as UML, although in some cases the use of such OS virtualization tools can help for the development of layer 3 protocols) and the Linux IP protocol stack is shared among nodes in the same physical machine. Nodes in the network communicate via direct-memory transfer when they are part of the same physical machine and via multicast IP over Ethernet when they are in different machines. Figure 18 below illustrates a generic architecture using the emulation environment.

Project:	SENDORA	Deliv. ref.:	D6.2
EC contract:	216076	Deliv. title:	Network dimensioning and protocol design
		Deliv. version:	1.0
		Submission date:	07/07/2009

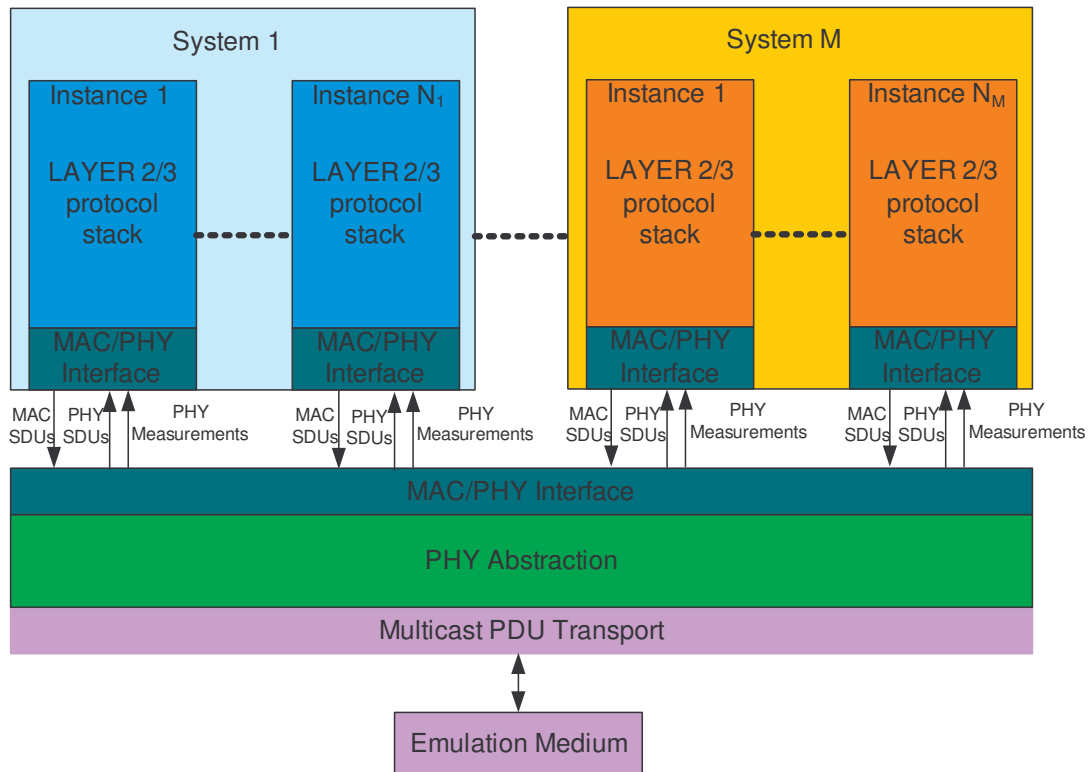

**Figure 19: System architecture based on emulation environment**

With virtualization of the protocol stack, many instances (on the order of 30 on a 2GHz Quad-core Xeon) can reside in the same physical machine. A typical setup for a large-scale emulation would consist of several PCs in a cluster network each housing tens of virtual nodes. The layer 3 networking protocols reside in the standard Linux kernel or user-space and are interfaced using a custom networking device driver. In a typical large scale emulation scenario a combination of real applications and traffic generators would be used. This targets large-scale repeatable emulations on a real protocol stack using real applications.

### 5.2.2.2 Scenario #1 implementation using emulator

For scenario #1 implementation, as nodes are sensors, performing sensing through their RF board, they will be at different places in the demonstration space. Consequently, their protocol stack for sensing information transmission will run on separate physical machines and communicate via multicast IP over Ethernet, as depicted on Figure 20 below. Sensing measurements will be carried to local CRRM via CRRC and then sent to FC CRRM through local CRRC and RLC/LMAC connected to the emulator.

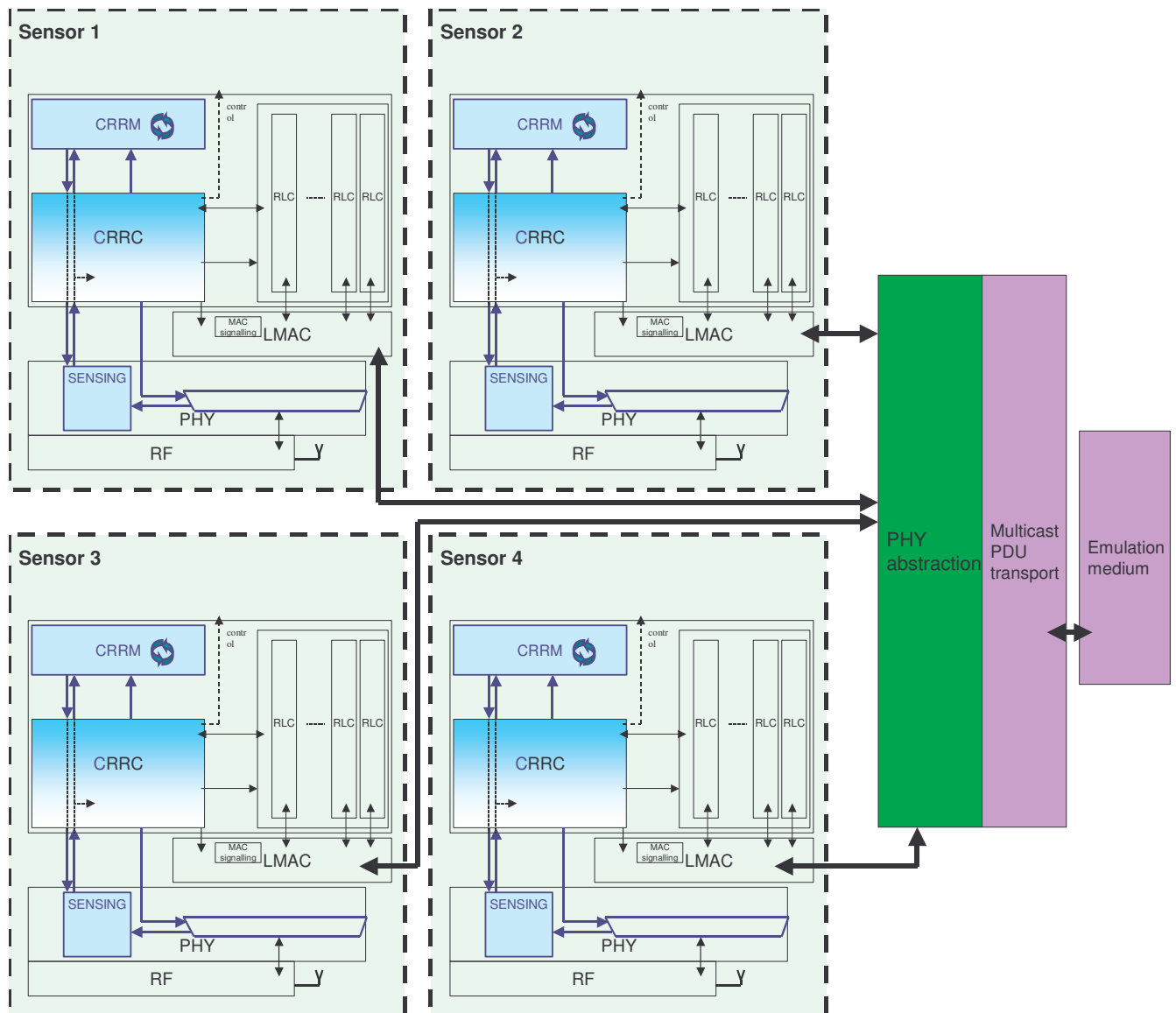

Figure 20: Demonstration scenario #1 implementation based on PHY emulation

## 5.3 SCENARIO #2

### 5.3.1 Sensors in Scenario #2

In system demonstration scenario #2, sensing capability is included in the secondary nodes. Thanks to this capability, the secondary network performs its own sensing, decision and adaptation in order to maximize their capacity without causing harmful interferences to the primary WLAN system. Secondary nodes form a clustered ad hoc network, in which this cognitive cycle is managed locally by the cluster head (the cluster head is intrinsically identical to the other nodes, but it takes this role because of the topology and neighborhood).

In this scenario, the sensing is performed using a dedicated RF which is also used for the communication of sensing information between nodes. The secondary cognitive communications are

Project:	SENDORA	Deliv. ref.:	D6.2
EC contract:	216076	Deliv. title:	Network dimensioning and protocol design
		Deliv. version:	1.0
		Submission date:	07/07/2009

performed using another dedicated RF to increase system reactivity to primary system activity. (Note that, thanks to this architecture, reactive and proactive behaviors - as described in section 2.3 - can be implemented). Terminal resources shall be synchronized to perform alternatively (as requested by the cluster head scheduling through beacon sending):

- sensing (frequency, bandwidth, time, ...),
  - transmission of sensing information (results of detection, according to the sensing requests) in both cooperative and non-cooperative communications mode,
- and simultaneously:
- secondary cognitive communications (according to sensing information aggregation and resulting decisions).

In this scenario, no independent sensor is considered, although some nodes may not communicate and only support sensing operation. This represents the recommended hybrid architecture mentioned in D2.1, composed of both sensing capacities in secondary nodes and through independent WSN.

In this scenario, the transmission of sensing information is performed over the air. Only sensor-to-cluster head (non-cooperative mode) and sensor-to-sensor or to-CH (cooperative mode) communications are considered. In a real system, a wired or wireless link to the FC should also be implemented for global spectrum control but it is not implemented here. Sensor-to-cluster head and sensor-to-sensor communications are conveyed on a dedicated narrow-band channel.

To perform cooperative communications, the protocol stack shall be modified to allow the broadcast of CSCH (CSCH<sub>i</sub> for each terminal). The terminals will be then able to receive the CSCH<sub>i</sub> from neighboring sensors to improve their local decision before to send it to the cluster head (aggregation of refined data) or to assist distributed sensing algorithms. This mode is introduced to design a complete protocol architecture but will be only implemented if resources allow it.

### **5.3.2 Stack implementation**

The protocol stack used in this scenario is the one depicted in Figure 18. Both sensing, sensing information transmission and secondary communications capabilities are used, which therefore means that both RF chains are used in this scenario.

Project:	SENDORA	Deliv. ref.:	D6.2
EC contract:	216076	Deliv. title:	Network dimensioning and protocol design
		Deliv. version:	1.0
		Submission date:	07/07/2009

## 6 SUMMARY AND FUTURE WORK

This report summarizes our efforts considering the dimensioning of the WSN to provide reliable spectrum sensing, the first steps of protocol design, and the design of the sensor platform used for the WP7 system demonstrations.

Traditional multi-purpose networks, like the Internet, have to provide the flexibility to use different technologies inside the network, while supporting also a wide range of applications. This calls for the strict definition of the protocol layers and the interfaces between the layers. This flexible architecture also means that a given application may not be served with the maximum possible efficiency. Sensor networks are different in the sense, that they are developed to support one or a couple of very similar applications, and at the same time have severe capability limitations in terms of bandwidth, processing and data storage capability. Therefore, protocol layers in sensor networks are often optimized with the specific application and specific hardware and radio capabilities in mind – which is often addressed as the cross-layer optimization of the protocol stack.

In this report we presented parts of a protocol stack that has to be specifically designed to support the spectrum sensing application. We discussed the protocols in isolation – apart from the issue of optimized sensor selection and routing. In the continuation of the project we will optimize the protocol parameters together, to provide the best performance for the given application and considering the available radio resources. Here we briefly introduce the necessary tasks of cross-layer optimization.

- The clustered architecture allows us to tune how distributed the spectrum allocation process should be. Small clusters lead to low inter-cluster traffic levels and transmission delays, while higher control traffic between the cluster heads is needed to collect information from the transmission area of the secondary users. The cluster size has to be optimized with respect to the available radio resources and the application delay limits.
- Error control solution has to be selected based on the specific traffic types in the sensor network. Periodic traffic will need forward error correction based error control (that is, increased redundancy), while some traffic between the secondary units and the fusion centre or cluster head may allow retransmission based error control. Similarly, strict TDMA based channel access may be combined with random access for some traffic types, e.g., for supporting secondary user channel requests.
- Redundancy for the periodic traffic can be introduced through channel coding (physical layer) or source coding (application layer) or both. This topic, together with the possibility of cooperative communication is addressed in general in WP5 and the results have to be moved to the protocol design in WP6. Coding has to be optimized together with the selected modulation technique to achieve the optimal relation of transmission rate and bit error probability.
- From sensing point of view the traffic level in the sensor network depends on the granularity of the information transmitted by the sensors (where the binary local decision is the extreme case), and on the area of cooperation for distributed sensing. As shown in Section 3, the efficiency of distributed sensing increases with including more sensors into the decision process and with increased information granularity. Considering the limit on the transmission resources, the cooperation level and information granularity have to be optimized together.
- Similarly, if a higher number of channels are sensed in the sensor network, the probability of finding available channel for cognitive operation increases, but the sensor network traffic level increases at the same time. Therefore the number of channels sensed has to be optimized together

Project:	SENDORA	Deliv. ref.:	D6.2
EC contract:	216076	Deliv. title:	Network dimensioning and protocol design
		Deliv. version:	1.0
		Submission date:	07/07/2009

with the above parameters of distributed sensing, considering the limit on the transmission resources.

The network dimensioning work up to now considered the requirements of reliable sensing only. These studies and related analytic models will be extended to also include the requirements of data fusion and secondary unit control, considering the amount of data to be collected and the acceptable control delay of the cognitive operation. This dimensioning however depends significantly on the details of the protocol design and therefore will be performed towards the end of the project.

Project:	SENDORA	Deliv. ref.:	D6.2
EC contract:	216076	Deliv. title:	Network dimensioning and protocol design
		Deliv. version:	1.0
		Submission date:	07/07/2009

## 7 REFERENCES

1. E. Visotsky, S. Kuffner, and R. Peterson, "On collaborative detection of TV transmissions in support of dynamic spectrum sharing," in Proc. of IEEE DySPAN, 2005.
2. A. Ghasemi and E. S. Souza, "Spectrum sensing in cognitive radio networks: the cooperation-processing tradeoff," *Wireless Communication and Mobile Computing*, 2007.
3. A. Ghasemi and E. S. Souza, "Collaborative spectrum sensing for opportunistic access in fading environments," in Proc. of IEEE DySPAN, 2005.
4. S. Chaudhari, V. Koivunen, and H. V. Poor, "Distributed autocorrelation-based sequential detection of ofdm signals in cognitive radios," in Proc. of CrownCom, 2008.
5. D. Cabric, A. Tkachenko, and R. W. Brodersen, "Experimental study of spectrum sensing based on energy detection and network cooperation," in Proc. IEEE MILCOM, 2006.
6. A. K. Kattapur, A. T. Hoang, Y-C Liang, and M. J. Er, "Data and decision fusion for distributed spectrum sensing in cognitive radio networks," in Proc. of ICICS, 2007.
7. F. Visser, G. J. M. Janssen, and P. Pawelczak, "Multinode spectrum sensing based on energy detection for dynamic spectrum access," in Proc. of IEEE VTC Spring, 2008.
8. S. M. Mishra, R. Tandra, and A. Sahai, "Coexistence with primary users of different scales," in Proc. of IEEE DySPAN, 2007.
9. W-Y. Lee and I. F. Akyildiz, "Optimal spectrum sensing framework for cognitive radio networks," *IEEE Transactions on Wireless Communications*, 7(10), 2008.
10. M. Timmers, et al., "Accumulative interference modeling for distributed cognitive radio networks," *Journal of Communications*, 4(3), 2009.
11. V. Fodor, I. Glaropoulos, and L. Pescosolido, "Detecting low-power primary signals via distributed sensing to support opportunistic spectrum access," in Proc of IEEE ICC, 2009.
12. I. Glaropoulos, V. Fodor, "On the efficiency of distributed spectrum sensing in ad-hoc cognitive radio networks," submitted, 2009.
13. S. Boyd and L. Vandenberghe., "Convex Optimization," Cambridge University Press, 2004.
14. C. Stevenson, G. Chouinard, Z. Lei, W. Hu, S. Shellhammer, and W. Caldwell, "Ieee 802.22: The first cognitive radio wireless regional area network standard," *Communications Magazine*, IEEE, vol. 47, pp. 130–138, January 2009.
15. T. Yucek and H. Arslan, "A survey of spectrum sensing algorithms for cognitive radio applications," *Communications Surveys and Tutorials*, IEEE, vol.11, pp.116–130, Quarter 2009.
16. D. Culler, D. Estrin, and M. Srivastava, "Guest editors' introduction: Overview of sensor networks," *Computer*, vol. 37, pp. 41–49, Aug. 2004.
17. H. Urkowitz, "Energy detection of unknown deterministic signals," *Proceedings of the IEEE*, vol. 55, pp. 523–531, Apr. 1967.
18. F. Digham, M.-S. Alouini, and M. Simon, "On the energy detection of unknown signals over fading channels," *Communications*, 2003. ICC'03. IEEE International Conference on, vol.5, pp. 3575–3579 vol.5, May 2003.
19. Z. Quan, S. Cui, H. Poor, and A. Sayed, "Collaborative wideband sensing for cognitive radios," *Signal Processing Magazine*, IEEE, vol. 25, pp. 60–73, November 2008.
20. H. Hashemi and I. Rhodes, "Decentralized sequential detection," *Information Theory*, IEEE Transactions on, vol. 35, pp. 509–520, May 1989.
21. B. Chen and P. Willett, "On the optimality of the likelihood-ratio test for local sensor decision rules in the presence of non-ideal channels," *IEEE Transactions of Information Theory*, vol. 51, Feb. 2005.
22. R. Viswanathan and P. Varshney, "Distributed detection with multiple sensors: Part 1 - fundamentals," *Proceedings of the IEEE*, vol. 85, pp. 54–63, Jan. 1997.
23. Z. Quan, S. Cui, and A. Sayed, "Optimal linear cooperation for spectrum sensing in cognitive radio networks," *IEEE Journal of Selected Topics in Signal Processing*, vol. 2, pp.28–40, Feb. 2008.
24. J. Ma and Y. Li, "Soft combination and detection for cooperative spectrum sensing in cognitive radio networks," *Global Telecommunications Conference, 2007. GLOBECOM'07. IEEE*, pp. 3139–3143, Nov. 2007.
25. N. Ahmed, D. Hadaller, and S. Keshav, "Guess: gossiping updates for efficient spectrum sensing," *International Conference on Mobile Computing and Networking*, pp. 12–17, Sept. 2006.

Project:	SENDORA	Deliv. ref.:	D6.2
EC contract:	216076	Deliv. title:	Network dimensioning and protocol design
		Deliv. version:	1.0
		Submission date:	07/07/2009

26. M. Gudmundson, "Correlation model for shadow fading in mobile radio systems," *Electronics Letters*, vol. 27, pp. 2145–2146, Nov. 1991.
27. F. P. Fontan and P. M. Espineira, *Modeling the Wireless Propagation Channel: A Simulation Approach with MATLAB*. Wiley, 2008.
28. K. Akkaya, M. Younis, "A survey on routing protocols for wireless sensor networks", *Ad Hoc Network*, Vol 3, pp. 325-349, 2005.
29. J. Bachrach and C. Taylor. *Handbook of Sensor Networks*, chapter Localization in Sensor Networks. Wiley, 2005.
30. C. Intanagonwiwat, R. Govindan, D. Estrin, J. Heidemann, and F. Silva. Directed diffusion for wireless sensor networking. *IEEE/ACM Trans. Networking*, 11(1):2–16, 2003.
31. S. Kulkarni and M. Arumugam. SS-TDMA: A Self-Stabilizing MAC for Sensor Networks, chapter In *Sensor Network Operations*. IEEE Press, 2005.
32. C. Schurgers and M.B. Srivastava, "Energy efficient routing in wireless sensor networks", in the *MILCOM Proceedings on Communications for Network-Centric Operations: Creating the Information Force*, McLean, VA, 2001.
33. Arunabha Sen, Tom Roxborough and Sirisha R. Medidi, "Upper and Lower Bounds of a Class of Channel Assignment Problems in Cellular Networks," In *Proceedings of IEEE Conference on Information and Communication (INFOCOM)*, vol. 3, pages 1284-1291, San Diego, CA, April, 1998.
34. B. Sundararaman, U. Buy, A. Kshemkalyani," Clock synchronization for wireless sensor networks: a survey", *Ad Hoc Networks (Elsevier)* 3 (3) (2005) 281–323.
35. Yan Yu, Ramesh Govindan, and Deborah Estrin. "Geographical and energy aware routing: A recursive data dissemination protocol for wireless sensor networks." *Technical Report TR-01-0023*, University of California, Los Angeles, Computer Science Department, 2001.

Project:	SENDORA	Deliv. ref.:	D6.2
EC contract:	216076	Deliv. title:	Network dimensioning and protocol design
		Deliv. version:	1.0
		Submission date:	07/07/2009

## 8. ACRONYMS

BS	Base Station
CCC	Common Control Channel
CH	Cluster Head
CPCH	Cognitive Pilot Channel
CRN-E	Cognitive Radio Network Entity
CSCH	Cognitive Sensing Channel
FC	Fusion Centre
ICH	Inter Cluster Heads Protocols
IS	Inter-Sensors Protocols
LAN	Local Area Network
LTE	Long Term Evolution
MAC	Medium Access Control
PDU	Packet Data Unit
PU	Primary User
PUN	Primary User Network
S2CH	Sensors to Cluster Heads Protocols
SU	Secondary User
WLAN	Wireless LAN
WSN	Wireless Sensor Network